

11th INTERNATIONAL SYMPOSIUM ON STEEL BRIDGES 2024

Latest developments in long span bridges

Henrik Polk - Technical Director
Bridges International, COWI

1 11-13 SEPTEMBER 2024

COWI

Long span bridges – own references

- > Cable stayed bridges - built
 - > Tappan Zee - 370m, New York 2017 (prepared for railway)
 - > Russky Bridge – 1104m, Russia 2012
present world record
 - > Chong Ming Yangtze River Bridge – 730m, China 2009
 - > Sutong Yangtze River Bridge – 1088m, China 2008
 - > Öresund bridge, - 490m Denmark 2000 (road and railway)
- > Cable stayed bridges – not built yet
 - > Bjørnafjorden Floating Bridge, $\frac{1}{2}$ span of 430m, Norway
- > Hybrid bridges (combined suspension- and cable stayed bridge) – built
 - > Yavuz Sultan Selim Bridge – 1408m, Türkiye 2016
present world record
- > Floating bridges – not built yet
 - > Bjørnafjorden Floating Bridge – 5400m, Norway



Long span bridges – own references

- > Suspension bridges - built
 - > 1915 Çanakkale Bridge – 2023m, Türkiye 2022
present world record
 - > Osmangazi Bridge – 1550m, Türkiye 2016
 - > Maputo-Katembe Bridge, Mozambique 2018
 - > Great Belt – 1624m, Denmark 1998
 - > Chacao Bridge – 2x1100m, Chile
(under construction)
 - > Zhanggao Bridge – 2300m, China
(under construction)
 - > ShiZiYang Suspension Bridge – 2180m, China
(under construction)
- > Suspension bridges – not built yet
 - > Messina Strait Bridge – 3300m, Italy
 - > Halså Fjord Suspension Bridge, 2000m, Norway
 - > Sula Fjord Suspension Bridge, 2000m, Norway
 - > Vartdalsfjorden – 2250m, Norway



New straits to pass – span lengths

- > Cable stayed bridges - max span length of 1104m since 2012 (Russky Bridge)
 - > Appears as max span length has been reached
- > Hybrid bridges – max span length of 1408m since 2016 (Yavuz Sultan Bridge)
 - > Bridge type substitutes a suspension bridge where vertical deck stiffness is essential – e.g. carrying a railway line
- > Suspension bridges - max span length of 2023m since 2022 (1915 Çanakkale Bridge)
 - > New bridges under construction increasing max span length to 2300m in 2026-28
 - > If construction of the Messina Bridge gets started in 2025, max span length will become 3300m
 - > Hypothetical - Gibraltar Crossing with 5000m main span

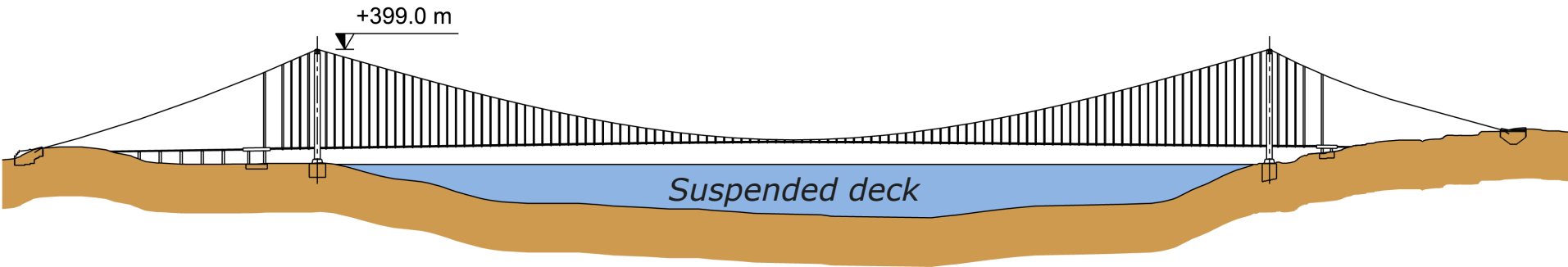

New straits to pass – span lengths

- > Straits of up to 5400m width - new concepts being developed for floating bridges
- > Interest from many sides, but it will take time to mature the projects
- > Main challenges are (Bjørnafjorden Bridge, Norway):
 - > Relatively high waves in combination with long period swell (15-30s)
 - > Floating bridges are not covered by the Eurocode system
 - > Complex correlation between wind and waves for bridge superstructure
 - > Ship impact – global impact, locally at piers, girder and pontoon walls
 - > Hydrodynamic pontoon design and risk of flooded pontoons
 - > Complex fatigue loading due to combined waves, wind and traffic
 - > Complex erection – long prefabricated bridge sections towed to site and connected
 - > All in all - complex design and construction



New straits to pass – ship traffic

- Larger ships and increased ship traffic
- Çanakkale Bridge used as example
 - 44,000 registered vessels passing the strait per year – potential increase
 - The traffic today includes 260,000DWT bulk carriers, 167,000DWT oil tankers and 16,000TEU container ships
 - The navigation clearance is 1600m wide by 70m high

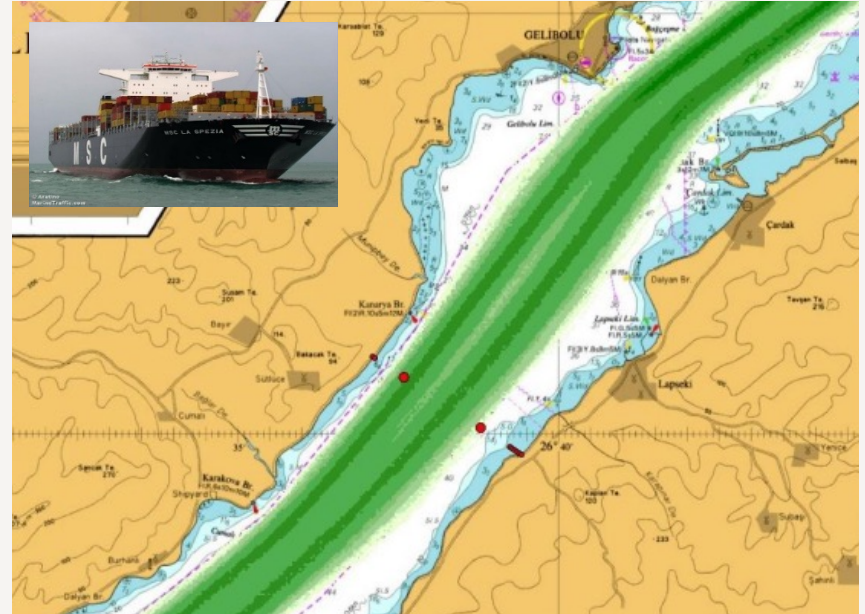
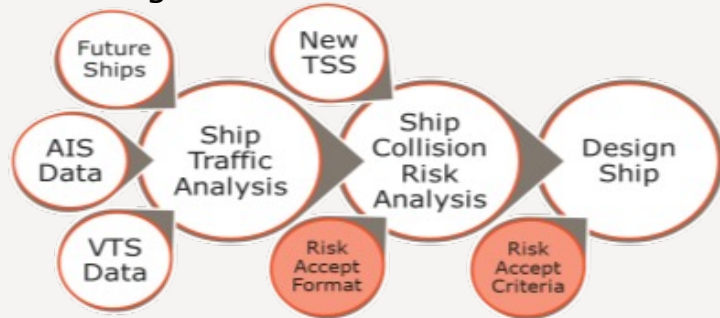

New straits to pass – ship traffic

- > Consider and design robust substructures
 - > Dynamic analysis performed in global FE-model to obtain the sectional forces from the global effect of the impact load
 - > Strict design criteria introduced to achieve minimal damage of non-accessible parts of foundations under accidental loads
 - > Lower part of steel tower and concrete plinth design are governed by ship impact



New straits to pass – stability of steel box

- > Increasing main span length giving challenges in respect to secure the deck flutter stability
 - > Simplified - flutter instability might happen at low wind speed if the 1st torsional frequency becomes too close to the 1st vertical frequency
 - > Increase torsion stiffness – make the steel box higher, or even better widen the steel box, or separate the steel box into two
 - > Mono-box girder - feasible up to typical 1800-2000m (2300m for Zhanggao Bridge) dependent on wind conditions and special additions
 - > Twin-box girder – typical beyond 1800-2000m

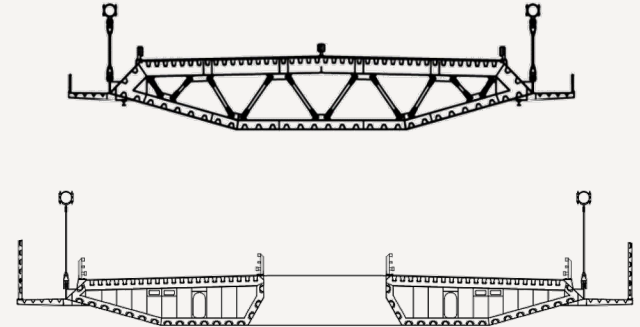

New straits to pass – mono-box aerodynamic

- > Flutter wind speed becomes a challenge for long span single box girders
 - > Keep angle of inclined bottom flange reasonable low
 - > Install guide vanes at the corner between bottom flange and inclined bottom flange - guiding the wind round the corner and thereby reduces vortex shedding
 - > Active design of safety barriers and parapets
 - > Vertical steel plate positioned at centre of deck and at bottom
 - > By above active measures the Zhanggao Bridge has been able to stretch the mono-box up to 2300m

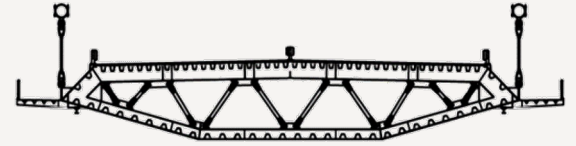

New straits to pass – stability of mono-box

> Typical mono-box girder layout - Osmangazi Bridge

Main span $L = 1550$ m

1:220 scale full bridge wind tunnel model

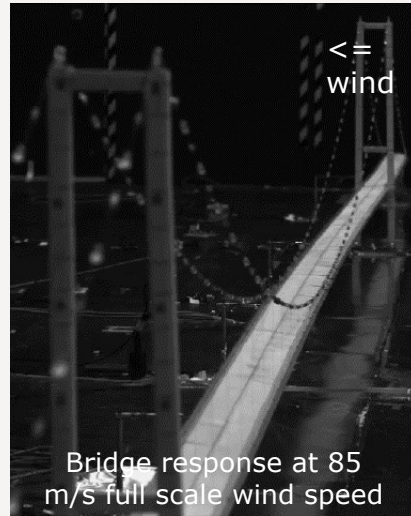

Bridge response at 85 m/s full scale wind speed

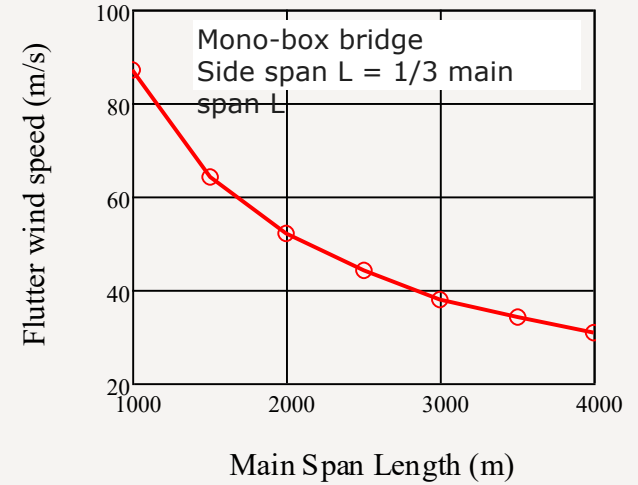
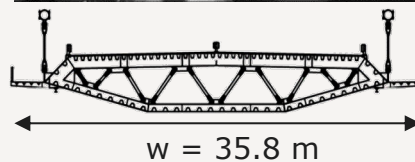

- Flutter wind speed requirement: 58 m/s

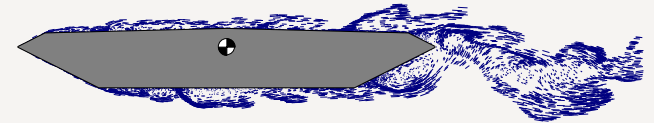

New straits to pass – stability of twin-box

> Typical twin-box girder layout - 1915 Çanakkale Bridge

Main span $L = 2023$ m



1:190 scale full bridge wind tunnel model

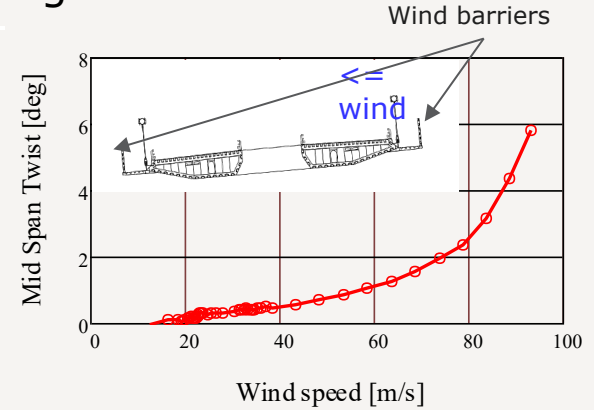

- Flutter wind speed requirement: 69 m/s

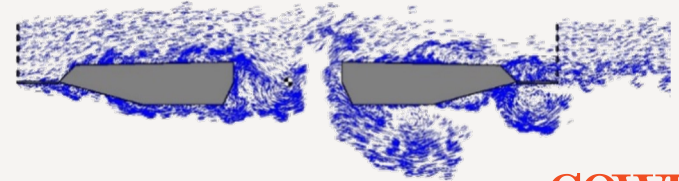
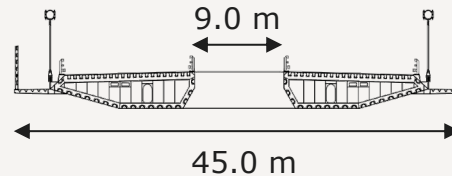

New straits to pass – twin-box aerodynamic

- > Flutter wind speed as function of deck angle of rotation relative to horizontal
- > The “nose-up effect”

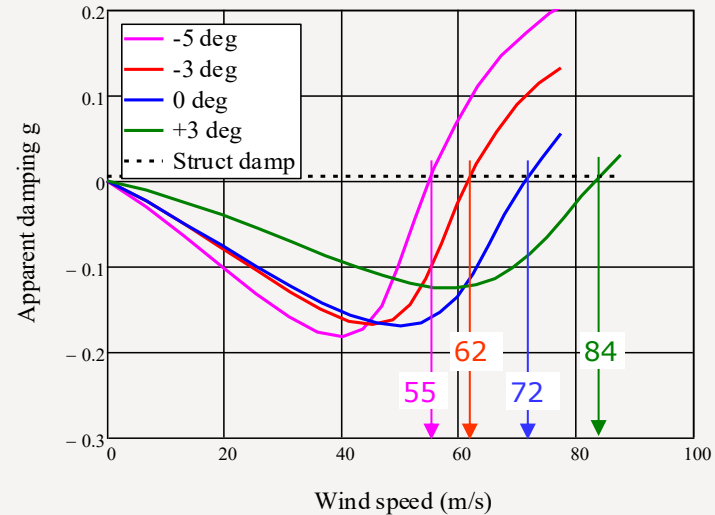
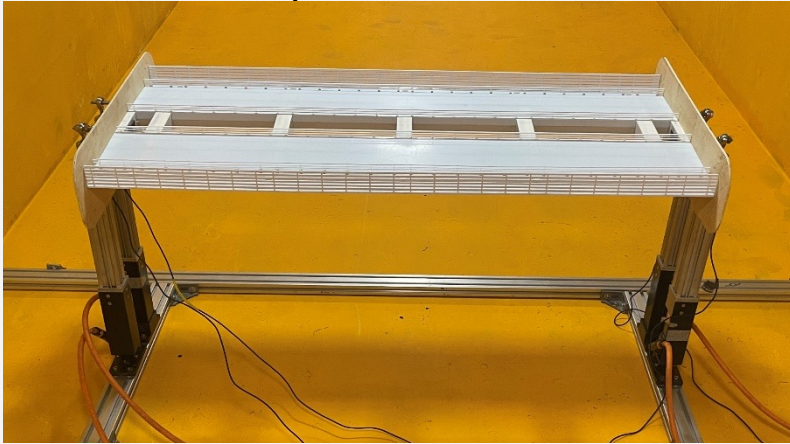

- > Higher wind speed – the more the deck will twist - “nose up effect”
- > Higher wind speed - the more the deck will rotate making the deck even more stable

New straits to pass - aerodynamic and wind tunnel tests

- > Aerodynamic modelling and testing of long-span bridges are essential obtaining the correct dynamic response of the bridge structure
- > Testing is necessary to investigate:
 - > Wind force coefficients (C_D, C_L, C_M) and derivatives
 - > Vortex shedding
 - > Galloping
 - > Flutter instability



New straits to pass - aerodynamic and wind tunnel tests

- > Typical wind tunnel testing:
 - > Tower section model (1:80 scale)
 - > Full tower model (1:225) and tower erection stages
 - > Deck section model at 1:60, followed later by 1:30
 - > Hanger vibration (1:1) and wake galloping
 - > Full bridge model (1:190) and deck erection stages

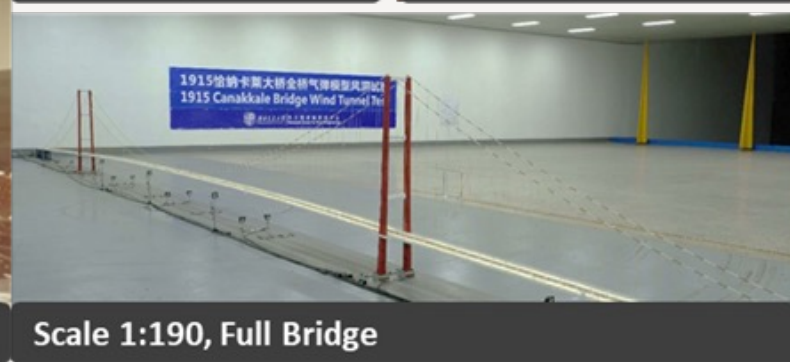
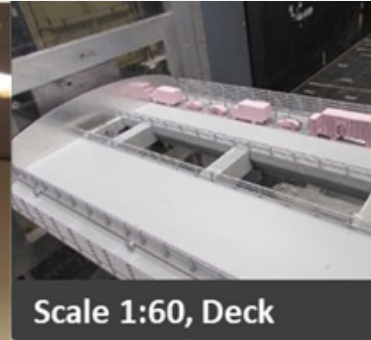

Environment – tower foundation

- > Tower foundations – often placed in water with poor ground conditions
 - > Investigate different concepts and evaluate in respect to experience, ship impact, seismic, track record, quantities, risk etc.
 - > Open dredged wells
 - > Pile cap + steel piles
 - > Space frame
 - > Caisson

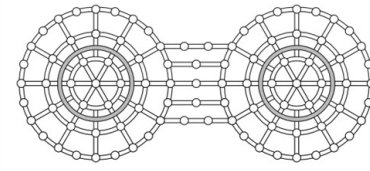
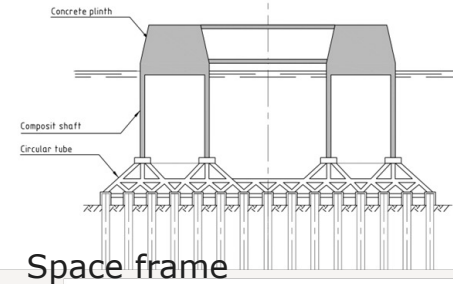
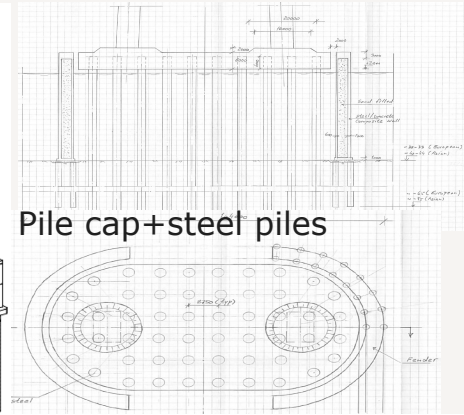
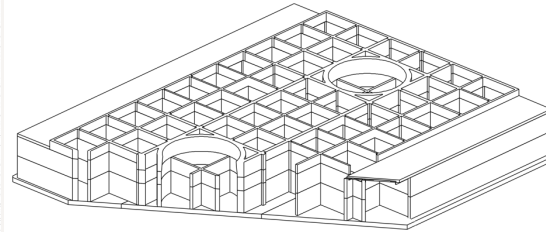
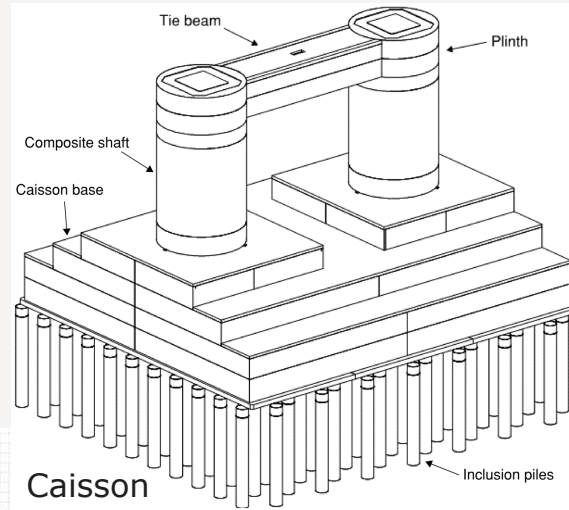
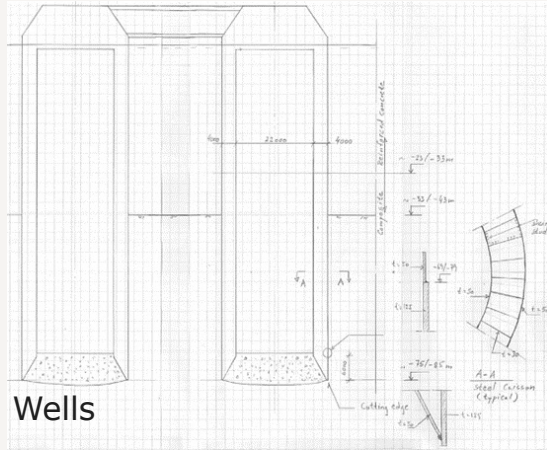

Environment – tower foundation

- › Often it ends with a caisson solution
 - › Robust for ship impact
 - › Robust for seismic overloading – can slide on the gravel bed placed on top of the inclusion piles
 - › Fast construction off site, work in parallel with construction site
- › Long steel inclusion piles are driven into the seabed
- › Caisson is placed on a gravel bed on top of steel inclusion piles
- › Settlement reduced and lateral resistance increased

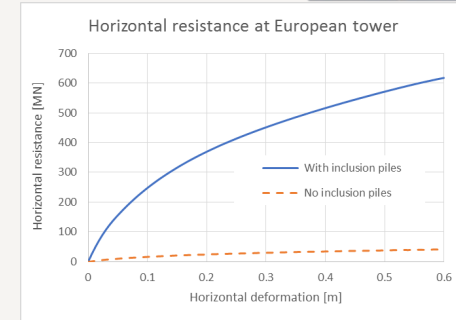
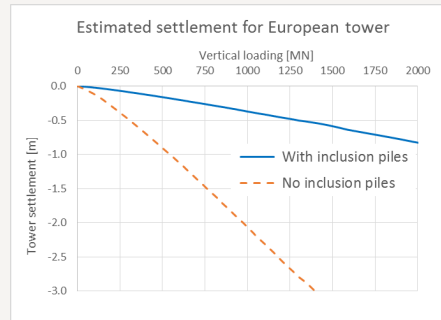
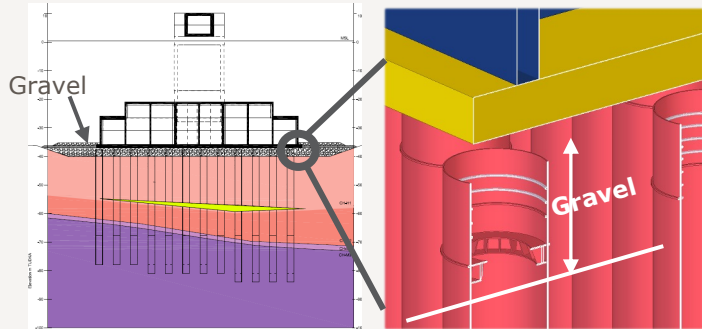
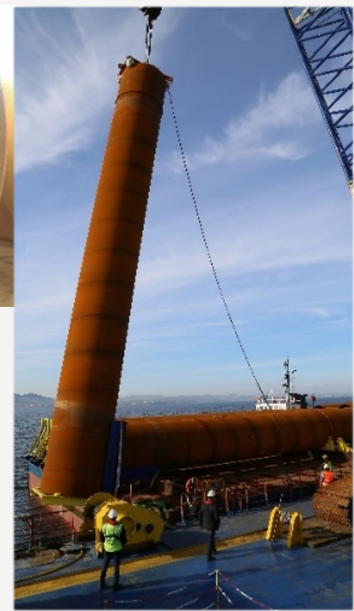

Environment - anchor blocks

- > Anchor block foundations – often placed in water or at shoreline also with pour ground conditions
 - > Investigate different concepts and evaluate in respect to experience, ship impact, seismic, track record, quantities, risk etc
 - > Massif inside diaphragm wall circle
 - > Two overlapping diaphragm wall circles, front legs on separate foundations
 - > Inclined shafts excavated and refilled with reinforced concrete
 - > Flat slab with features

Massif

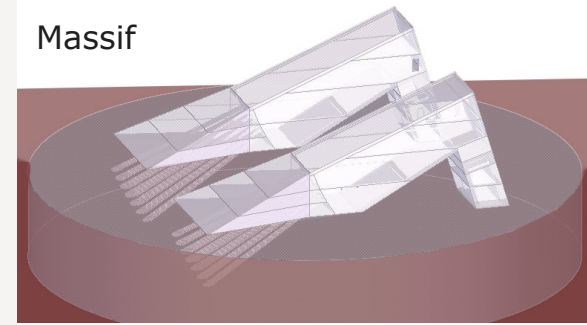

Two diaphragm walls, separate legs foundation

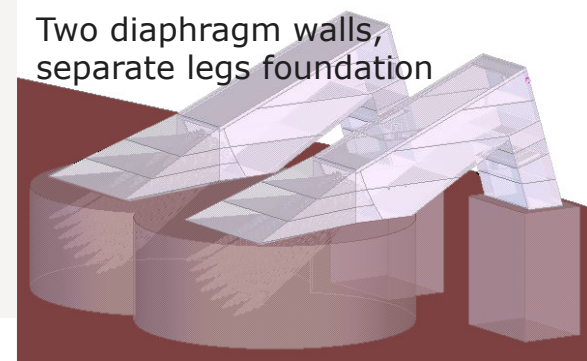

Inclined excavated shafts

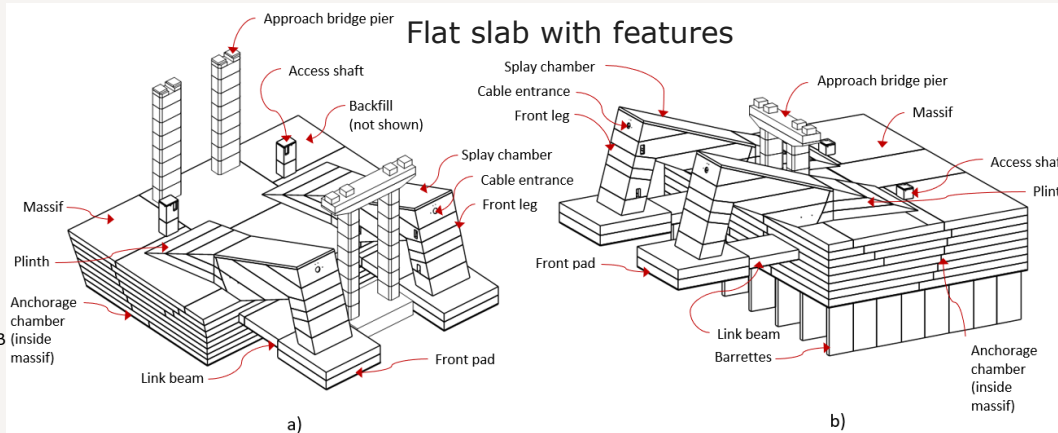
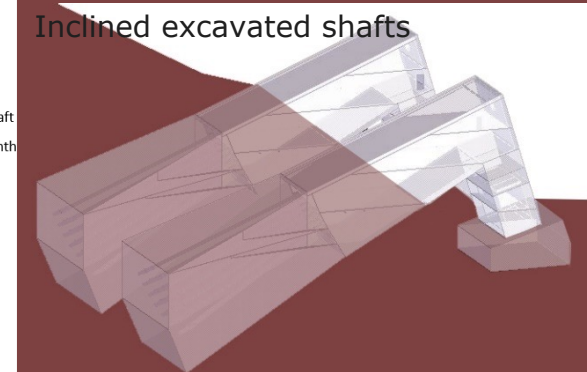

Environment- anchor blocks

- > Ended moving anchor block “up” and some 300m further inland and choose the slab solution with features
 - > Flat massif with individual front legs
 - > Backfill can act as counterweight
 - > Diaphragm walls to increase shear capacity
 - > Excavation without major temporary support
 - > Concrete quantities reduced by 50% and thereby also saving in construction time
 - > Additional costs are longer main cables and tie down arrangement at side span piers (modified bridge articulation)

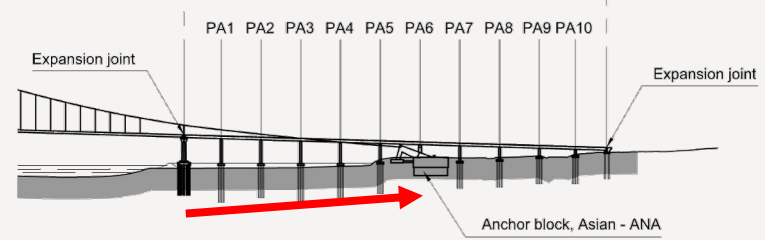
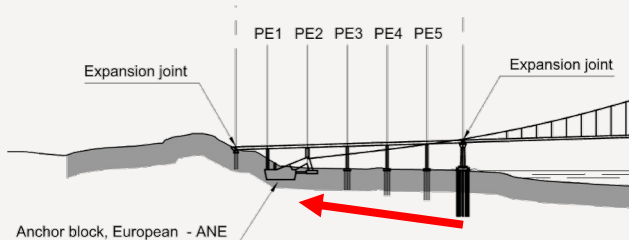

Environment - seismic analysis

- › Design criteria typical considers 3 potential events:
 - › Functional evaluation earthquake (FEE) – 145 year return period
 - › Safety evaluation earthquake (SEE) – 975 year return period
 - › No-collapse earthquake (NCE) – 2475 year return period
 - › For inaccessible substructures a stricter requirement is often introduced following the SEE

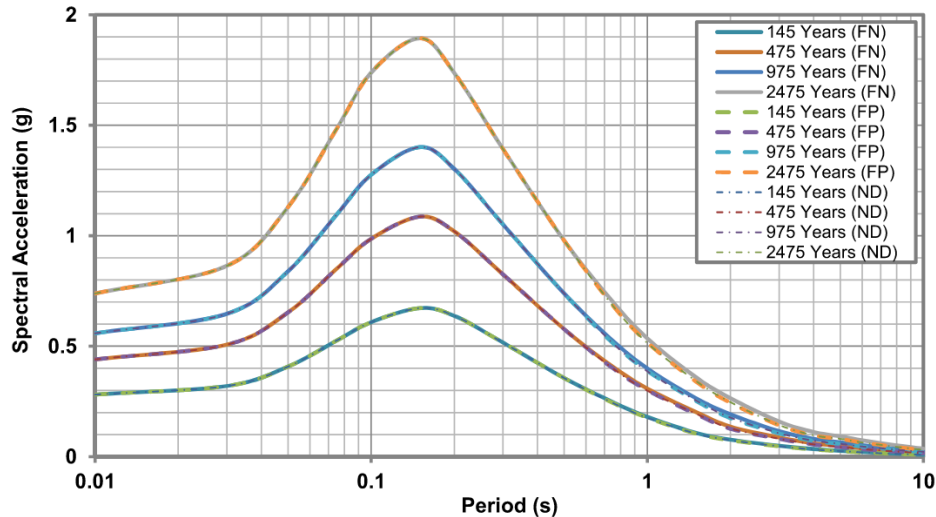

Environment - seismic analysis

- Important to investigate the non-linear behavior using 7 sets of earthquakes - EC then allows to use average for design
 - Time-displacement actions in three directions at six main bridge supports - see figure below
 - The analyses to verify sufficient capacity of bridge inclusive hydraulic buffers, tower wind bearings, end stops and soil-structure interaction
 - Anchor blocks and tower caissons often partly governed by seismic
 - Towers (steel) govern partly by seismic when in "high seismic zones"

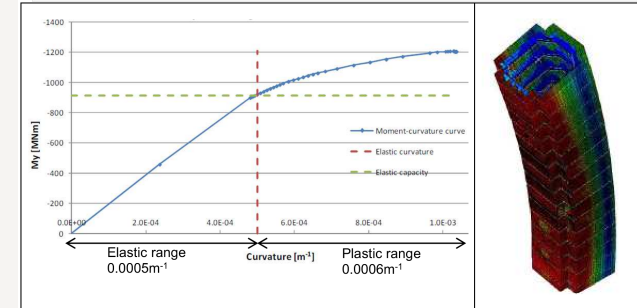
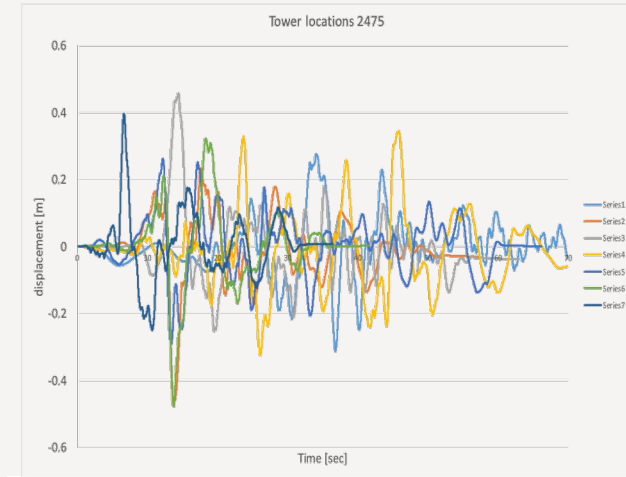

Tower – plastic design in NCE

Traffic loading - road

Global road traffic loading - uniformly distributed load (UDL)

- > Loaded lengths < 200 m, UDL = 81.8 kN/m
- > Eurocode 1991-2 load model 1, 2 and 3

(1) Load models defined in Clause 6 should be used for the design of road bridges with loaded lengths less than 200 m.

NOTE 1 200 m corresponds to the maximum length taken into account for the calibration of Load Model 1 (see 6.3.2). In general, the use of Load Model 1 is safe-sided for loaded lengths over 200 m.

NOTE 2 Load models for loaded lengths greater than 200 m can be defined in the National Annex.

Eurocode miss reduction in road traffic loading for long span bridges

- > Loaded lengths > 200 m - UDL = 58.8 kN/m
- > By using EN 1991-2 SE-NA (TRVK Bro 11 - taking effect of long loaded length into account)

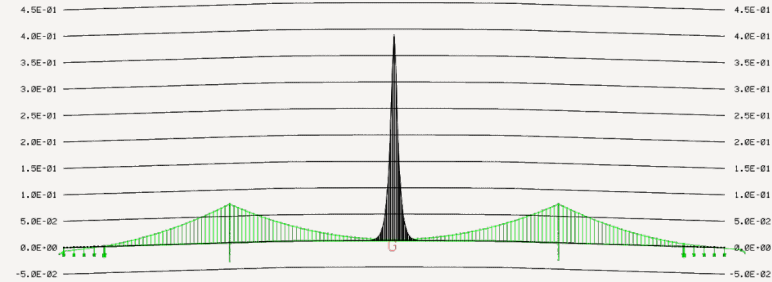

Influence on normal force in hanger

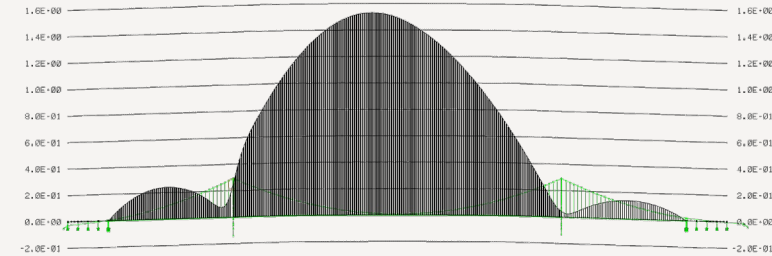

Influence on normal force in main cable

Traffic loading – road fatigue

- > Optimised deck design for modern cable supported bridges require detailed fatigue verifications of the orthotropic steel deck
- > The detailed fatigue verifications should be based on full stress histories for individual vehicles
- > The full verification is made within the global parametric FE-model!
- > Verification using the normal fatigue categories or the more refined hot spot method
- > How to improve fatigue life will be presented in coming slides

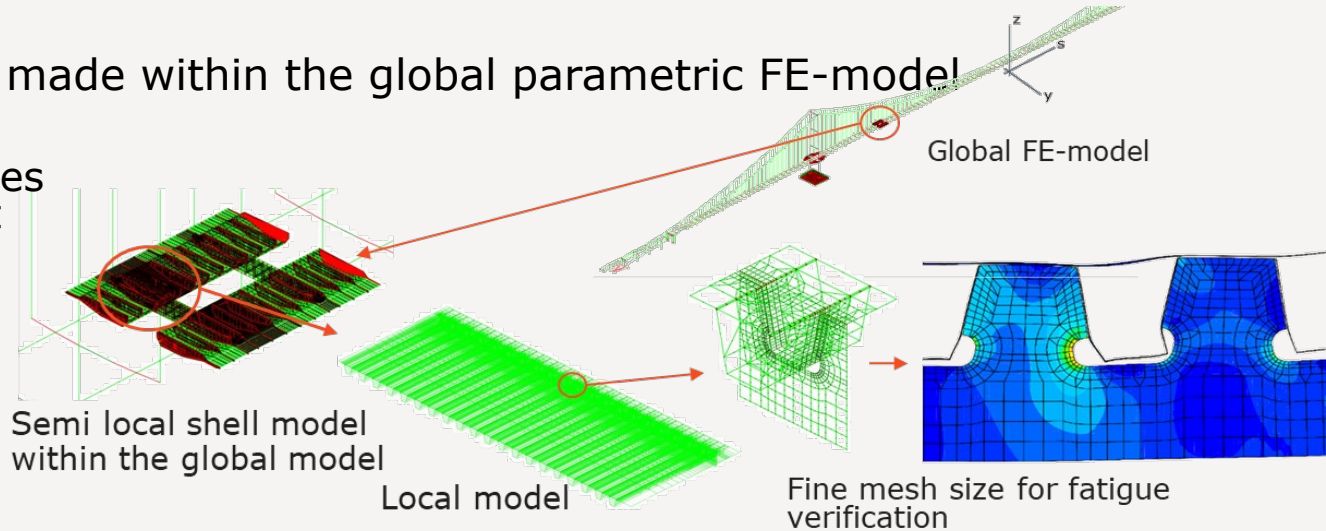

Traffic loading – impact from fatigue

- Many long span bridges experience fatigue problems after 20-50 years in service
 - Deck plate typical 12mm and trough 6mm
 - Cracks often initiate at diaphragms in heavy lane near the expansion joints and propagates into the deck structure over the years
 - Heavy traffic increases rapidly
 - New axle configurations with increased loading
 - Welding techniques, requirements and NDT have however also improved since designs

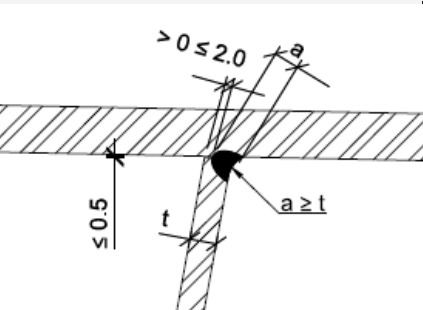
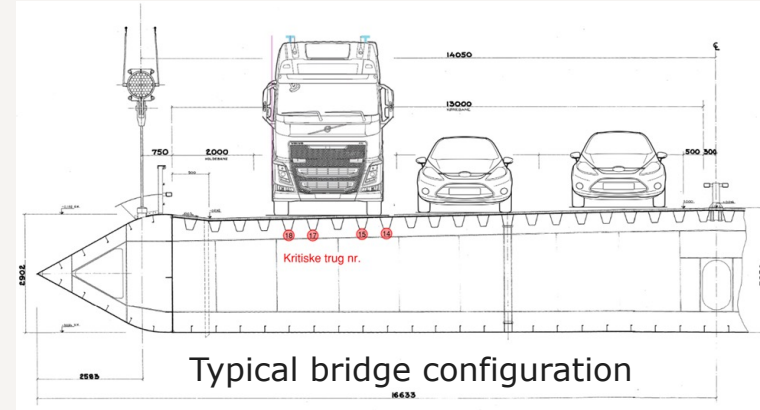

Typical trough to deck detail



Crack propagates from diaphragm



Repair by TIG - outside trough



Repair by TIG - root side, inside trough

Traffic loading – improve fatigue durability

- > Increase deck plate and troughs in heavy lanes to say 14-16mm deck plate (perhaps even more) and 7-8mm troughs – already done for most new designs
- > Double-sided welding of troughs to deck – being done China
 - > Own preliminary investigations suggest 50% increase in design life
 - > Perhaps above can also be done for repair works when asphalt shall be renewed. Troughs shall then be continuously without inside obstructions. This could be a problem for bolted troughs

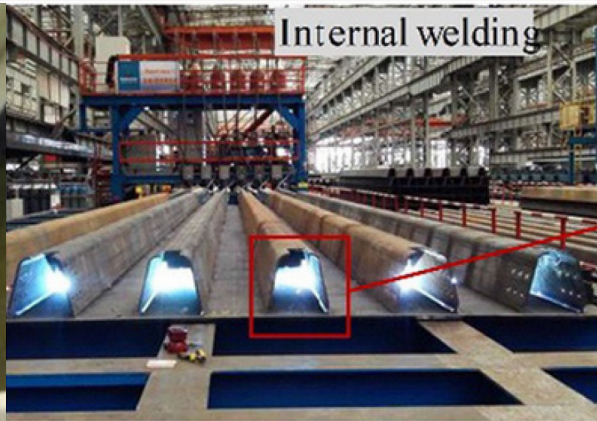
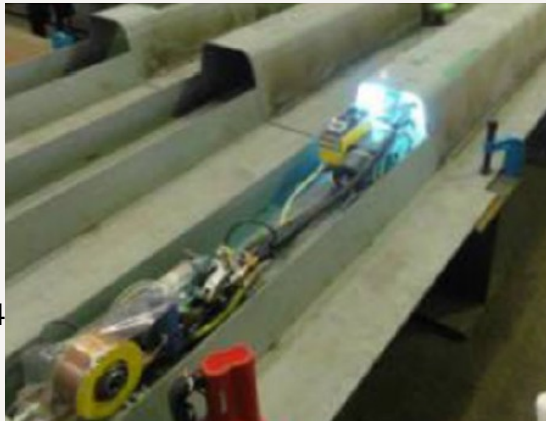
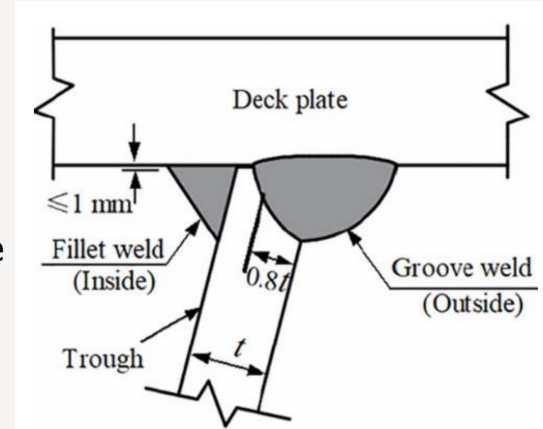

Traffic loading – improve fatigue durability

- › Thickened edge of troughs from 8mm to 12mm
 - › Partial weld, fully welded from one or two sides

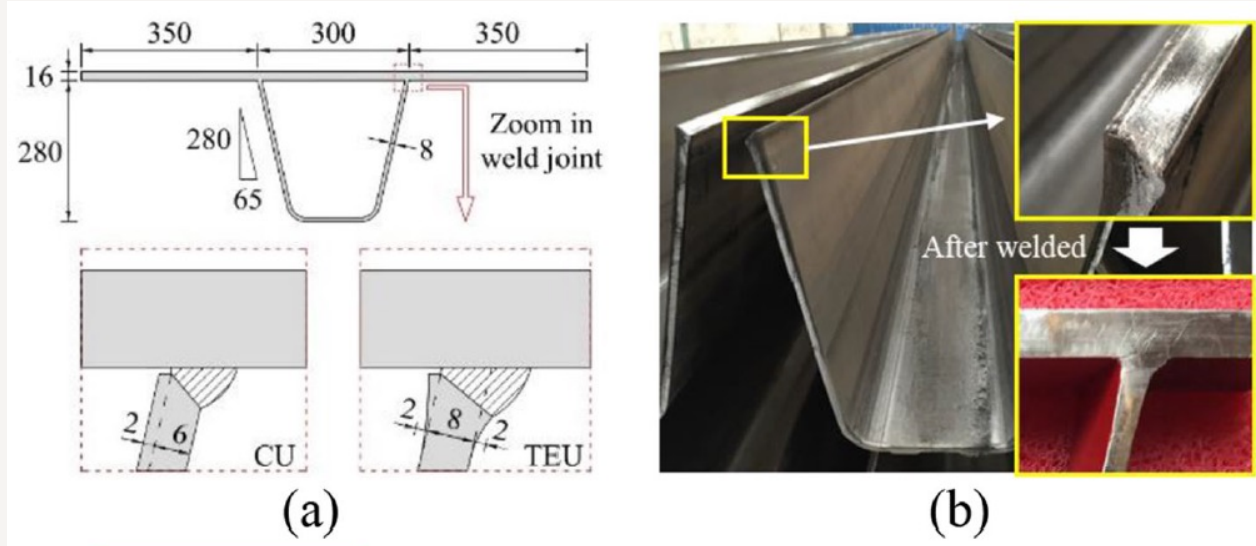

Traffic loading – improve fatigue durability

- › Better weld quality by new welding techniques - robot welding, laser hybrid welding and automated NDT methods
 - › Improve weld uniformity and quality
 - › Fully welding of deck to trough joints from one or two sides
 - › Automated NDT – less defects
 - › Use of Artificial Intelligence (AI) in welding and NDT process

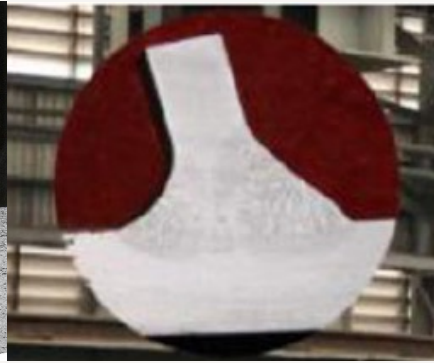

Traffic loading – improve fatigue durability

- > Increase deck stiffness and improve its isotropic properties
 - > No light break through alternatives have yet been found to replace the light 70 year old "orthotropic steel deck"
 - > Use stiffer asphalt types
 - > Use high performance concrete – fibre or stainless steel net

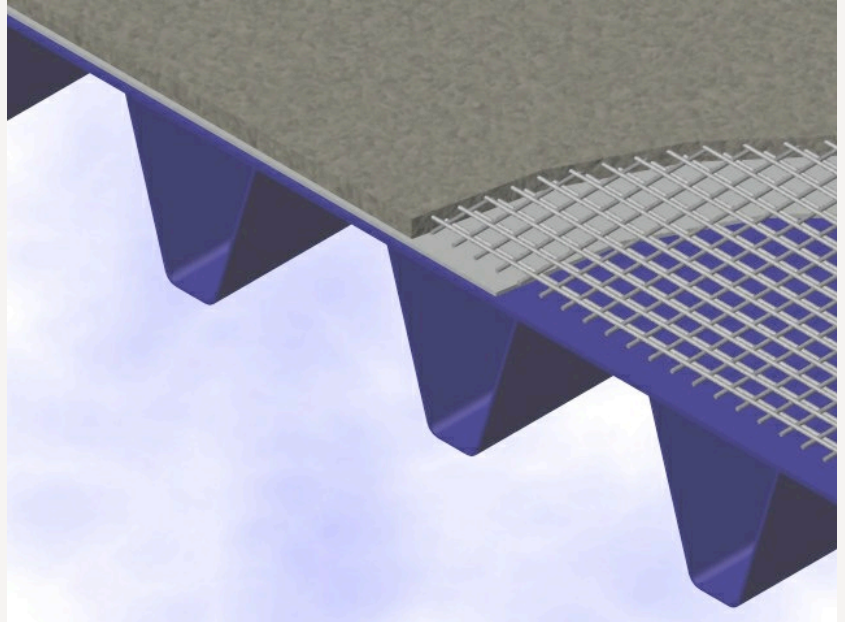

Traffic loading – rail and rail fatigue

- > A stiff deck structure is essential when designing long span bridges for rail traffic
- > High truss girder structure is often used, alternatively the new hybrid bridge type
- > Complex analyses to be performed:
 - > Simulating trains passing over bridge structure by use of dynamic properties for the trains
 - > Verification of the bridge performance
 - > Train derailment and overturning
 - > Comfort analysis
- > Railway fatigue
 - > In principle as for road



Materials – concrete substructures

- > The concrete substructures are designed and optimised directly in the global FE-model
 - > Modelling in one global parametric FE-model with integrated local models
 - > Boundaries becomes correct when having only one FE-model
 - > Automatic load application – beneficial for all models
 - > Tower foundations – often done by shell modelling
 - > Anchor blocks – often done by combination of 3D-solid modelling and shell modelling

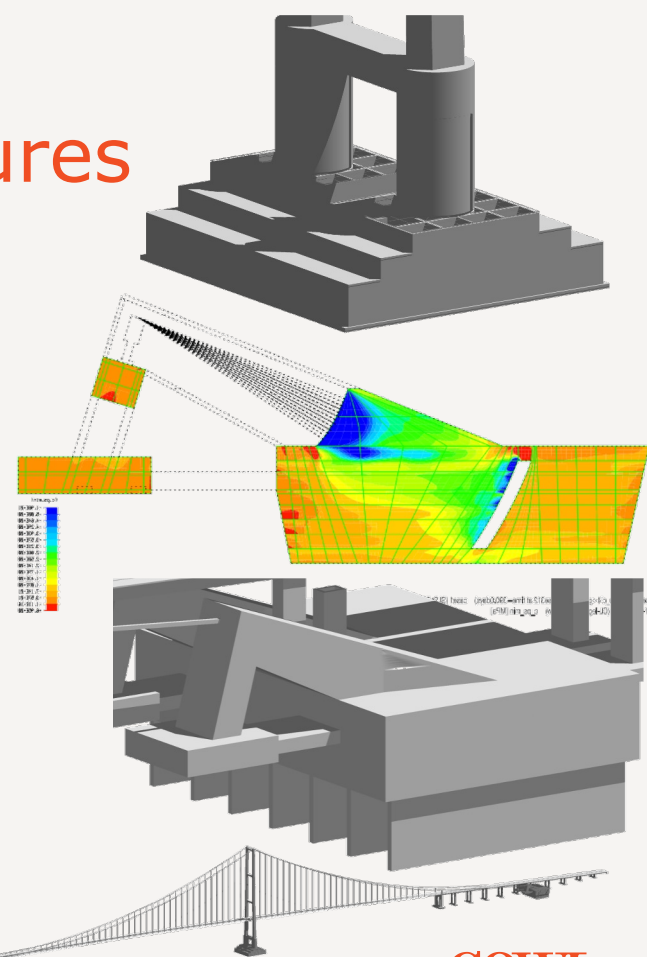

Materials – cable structures

- > Cable structures consist of main cables, splay- and tower saddles and hangers
 - > Main cable
 - > Up to 80% of loading in main cable is bridge self-weight, remaining almost from traffic – keep deck self weight to a minimum
 - > Air spinning replaced by Prefabricated Parallel Wire Strands (PPWS)
 - > Less number of strands gives faster erection - coils of 120 tons used for the Çanakkale Bridge
 - > Each strand is pulled from one anchor block to the other giving faster cable erection compared to air spinning
 - > Strand is hexagon shaped and has a red wire – easy to see if twisted
 - > Wires - breaking strength of 1960MPa, but 2060MPa and 2160MPa might soon come into designs. 2060MPa already used in China
 - > The main cable (D=850mm for Çanakkale Bridge, D= 1150mm for Zhanggao Bridge) is often protected by elastomeric wrapping and dehumidified ensuring a long design life
 - > Main cable diameter can be increased beyond 850mm without major challenges. Already being done I China

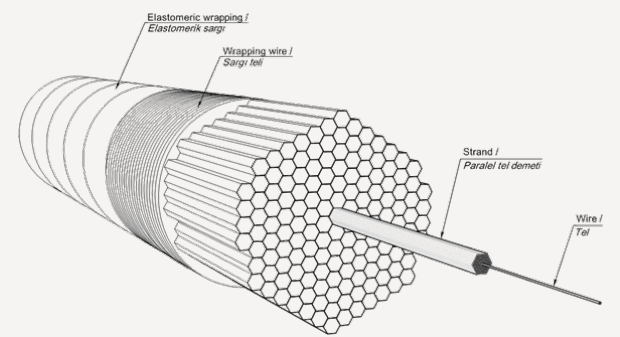

Materials – cable structures

- > Splay saddles, tower saddles and clamps
 - > The trough parts are often manufactured in high strength cast-iron (G24Mn6+QT2/3) in combination with welded steel plates S460. Be careful not to go too thin in casting thickness
- > Hangers
 - > Parallel Wire Strand (PWS) type is used covered by HDPE sheeting (often in strength 1770MPa). PWS is stiffer than lock-coil cables earlier used

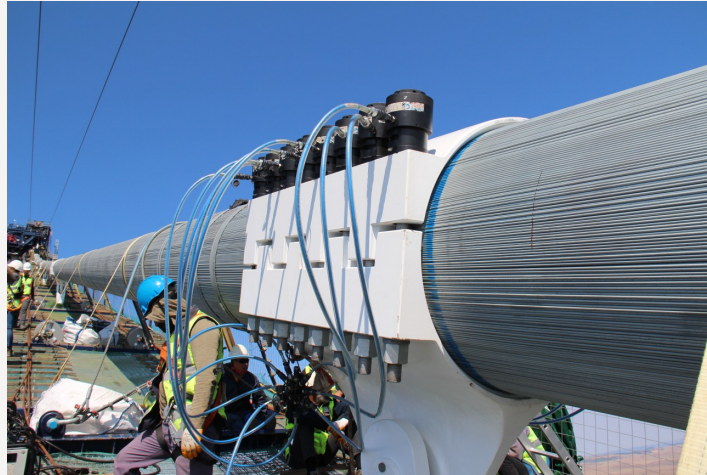
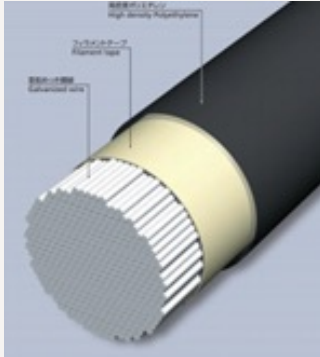

Materials – steel structures

- Most common steel materials utilised are S355 to S460
- S550 was however introduced on the Çanakkale Bridge to overcome corner stresses due to Vierendeel effect of the twin-box girder

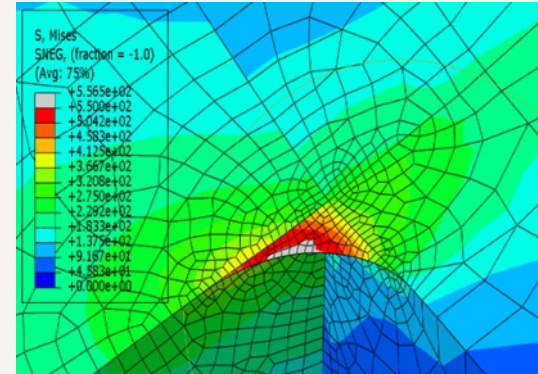
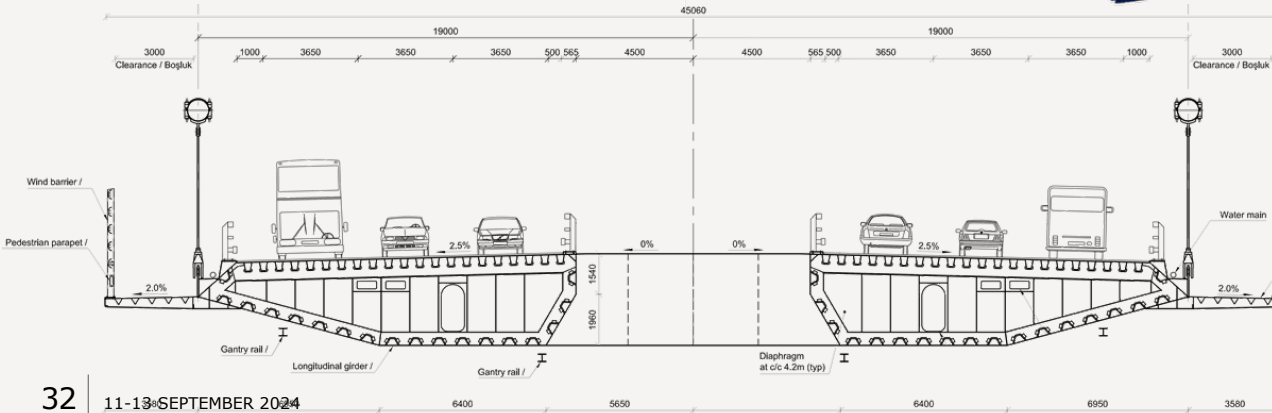
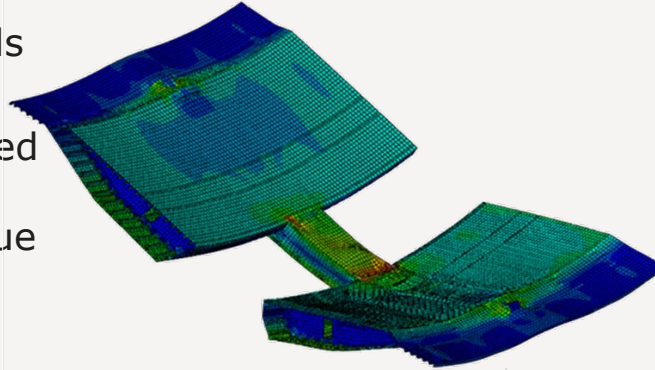

Materials – steel structures

- › S680 was utilised in splice plates connections of the Çanakkale tower
- › It is foreseen that milling of steel plate within the range S355 to S460 can be done without reduction in yield strength due to thicknesses increase
- › The high-performance steel mills can already deliver above increased quality, but contractors are reluctant as one might narrow the competition
- › Alternatively use S500 which was introduced 2019 in EN 10025-4
- › Another way is to use actual yield strength documented in the certificates. This has already partly been utilised
- › Less use of materials means less CO₂



© Danish Standards Foundation

DS/EN 10025-4:2019+A1:2022

EN 10025-4:2019+A1:2022 (E)

Table 4 – Mechanical properties – Tensile test properties at room temperature

Designation		Minimum yield strength R_{eH} ^a MPa						Tensile strength R_m ^a MPa					Minimum percentage elongation after fracture ^b % $l_0 = 5.65 \sqrt{S_0}$
Steel name	Steel number	Nominal thickness mm						Nominal thickness mm					
		≤ 16	> 16 ≤ 40	> 40 ≤ 63	> 63 ≤ 80	> 80 ≤ 100	> 100 ≤ 150	≤ 40	> 40 ≤ 63	> 63 ≤ 80	> 80 ≤ 100	> 100 ≤ 150	
S275M S275ML	1.8818 1.8819	275	265	255	245	245	240	370 to 530	360 to 520	350 to 510	350 to 510	350 to 510	24
S355M S355ML	1.8823 1.8834	355	345	335	325	325	320	470 to 630	450 to 610	440 to 600	440 to 600	430 to 590	22
S420M S420ML	1.8825 1.8836	420	400	390	380	370	365	520 to 680	500 to 660	480 to 640	470 to 630	460 to 620	19
S460M S460ML	1.8827 1.8838	460	440	430	410	400	385	540 to 720	530 to 710	510 to 690	500 to 680	490 to 660	17
S500M S500ML	1.8829 1.8839	500	480	460	450	450	450	580 to 760	580 to 760	580 to 760	560 to 750	560 to 750	15

^a For plate, strip and wide flats with widths ≥ 600 mm the direction transverse (t) to the rolling direction applies. For all other products the values apply for the direction parallel (l) to the rolling direction.

^b For product thickness < 3 mm for which test pieces with a gauge length of $l_0 = 80$ mm shall be tested, the values shall be agreed upon at the time of the order.

Bridge articulation system

An optimised design requires that the articulation system is considered correctly in the global FE-modelling

> Bridge articulation system:

- > Expansion joints – often at bridge ends
- > Vertical and lateral bridge bearings at bridge ends
- > Lateral wind bearings at towers
- > Hydraulic buffers and end stops for control of the longitudinal displacements of the deck - located at towers or bridge ends



Bridge articulation system

Long span bridges give large movements for in-service loads (traffic, temperature, wind) and seismic actions

> Hydraulic buffers:

- > restrain bridge deck for fast passing trucks and buffeting wind
- > reduction of movements giving extended lifetime of sliding elements
- > allow free movement of deck for temperature and static traffic loads giving reduced reaction forces in the structures
- > viscous damping during seismic events dissipating energy and controlling movements and forces

> Hydraulic end stops:

- > limit expansion joint movements to a manageable level

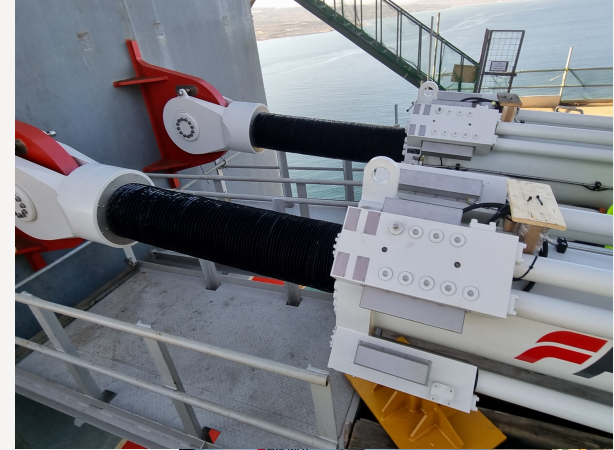

FE-modelling – global, semi local and local

The global parametric FE-model using a combination of beam, shell and solid elements

- > Local models are activated inside the global model with correct loading/boundary conditions
- > Fast design updates and changes giving a refined and optimised design
- > Fast output with consequences - quantities and CO₂

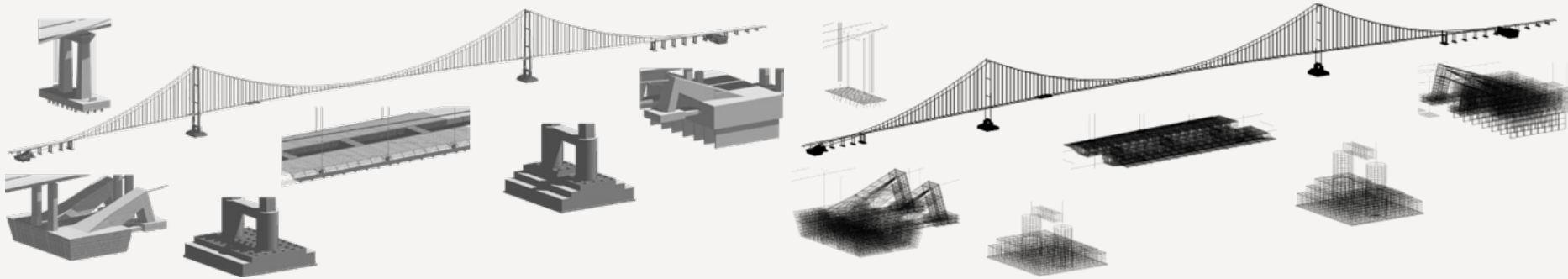

Design conditions

- › Long span signature bridges - often more complex
- › Design shall have less impact on environment
- › Optimised pricing, fast and safe construction
- › Example here taken from 1915 Çanakkale Bridge:
 - › Close collaboration between designer & contractor
 - › Extensive focus on alignment, anchor block location, layout and quantities. In parallel decide on tower foundation layout, fabrication and floatability
 - › Parallel works streams – e.g. installation of inclusion piles and casting of caissons
 - › Being able to design and construct in parallel
 - › Steel towers, main cable and deck segments prefabrication in large units. Fast erection on site using huge tower cranes, floating cranes and special made lifting gantries

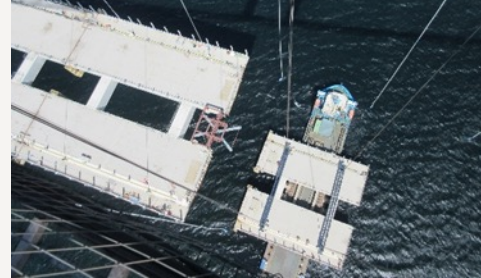

Operational conditions

- Longer service life and service life extension for existing bridges
 - Install dehumidification of main cables and deck
- Structural health monitoring and digital twins
 - A fundamental requirement for carrying out proactive operation and maintenance is to be able to predict the bridge performance
 - The aim is also lower maintenance costs
- Less bridge downtime
 - Installation of wind screens and control bridge dynamics in windy conditions, dynamic traffic signs etc.
- Maintenance having less impact on environment

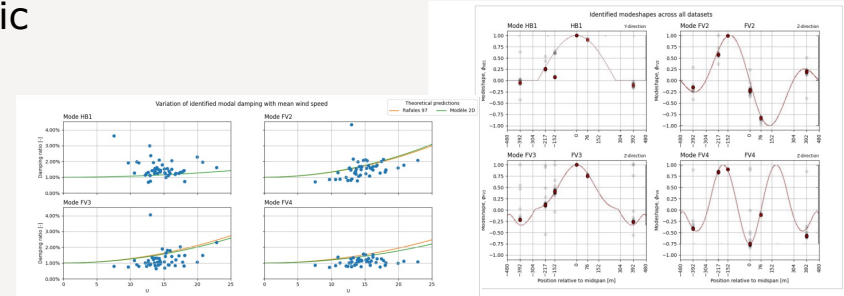

11th INTERNATIONAL SYMPOSIUM ON STEEL BRIDGES 2024



11th INTERNATIONAL SYMPOSIUM ON STEEL BRIDGES 2024





Thanks